

# SPA 20-100

*... compact and flexible*

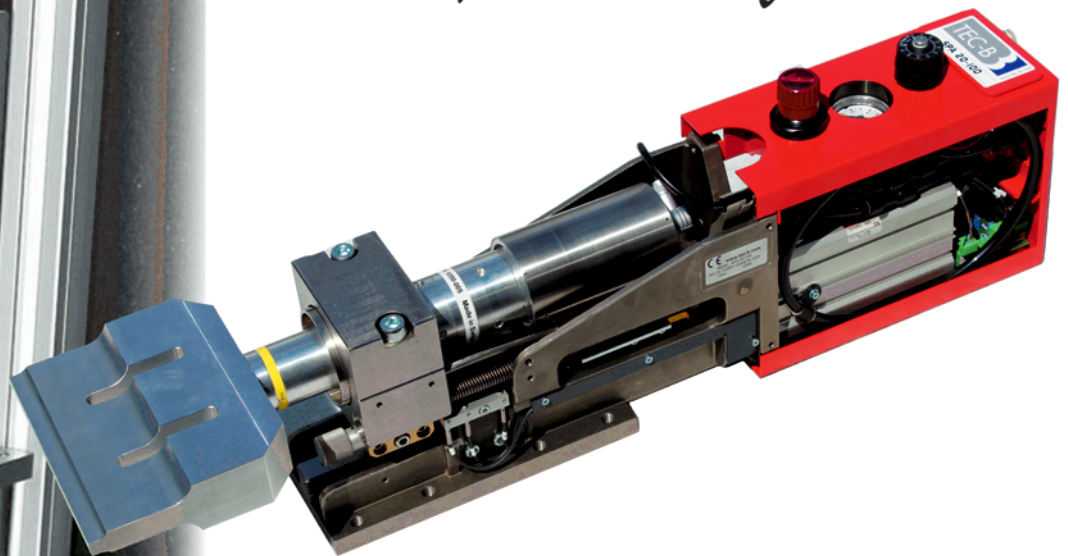

## 20kHz Ultrasonic Actuator

Conceived for easy adaptation in customer specific welding systems with user-friendly interfaces.

Available as basic module or enhanced system with functionality of a welding press.

Compact design with small outline dimensions for easy installation in welding units and special machines.

## Options:

Retrofittable options, with minimal increase of module overall size:

- Protective cover
- Travel measurement system

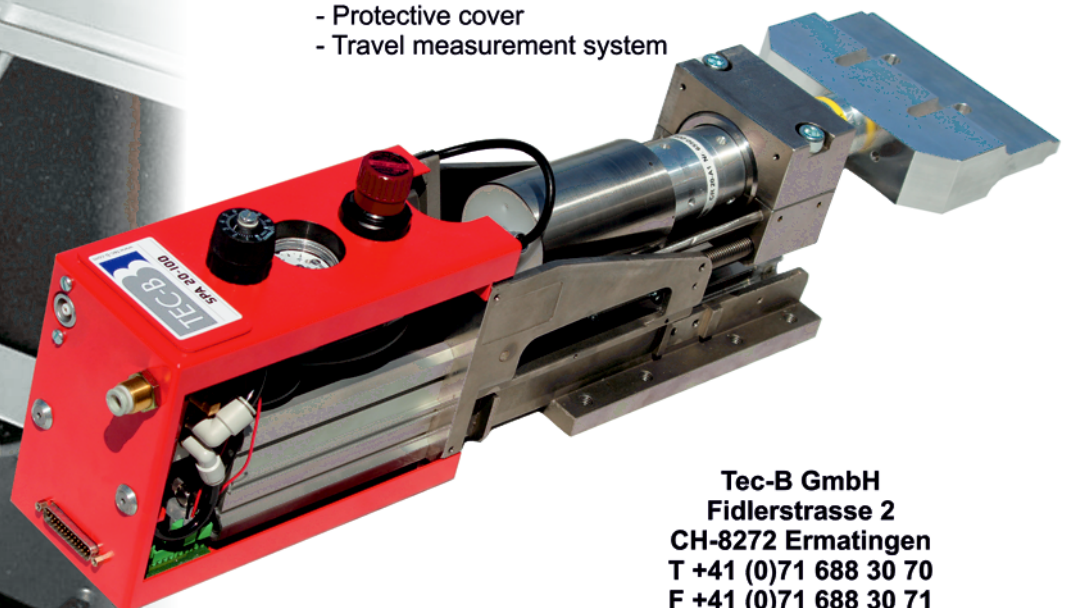

Tec-B GmbH  
Fidlerstrasse 2  
CH-8272 Ermatingen  
T +41 (0)71 688 30 70  
F +41 (0)71 688 30 71  
info@tec-b.com

# SPA 20-100

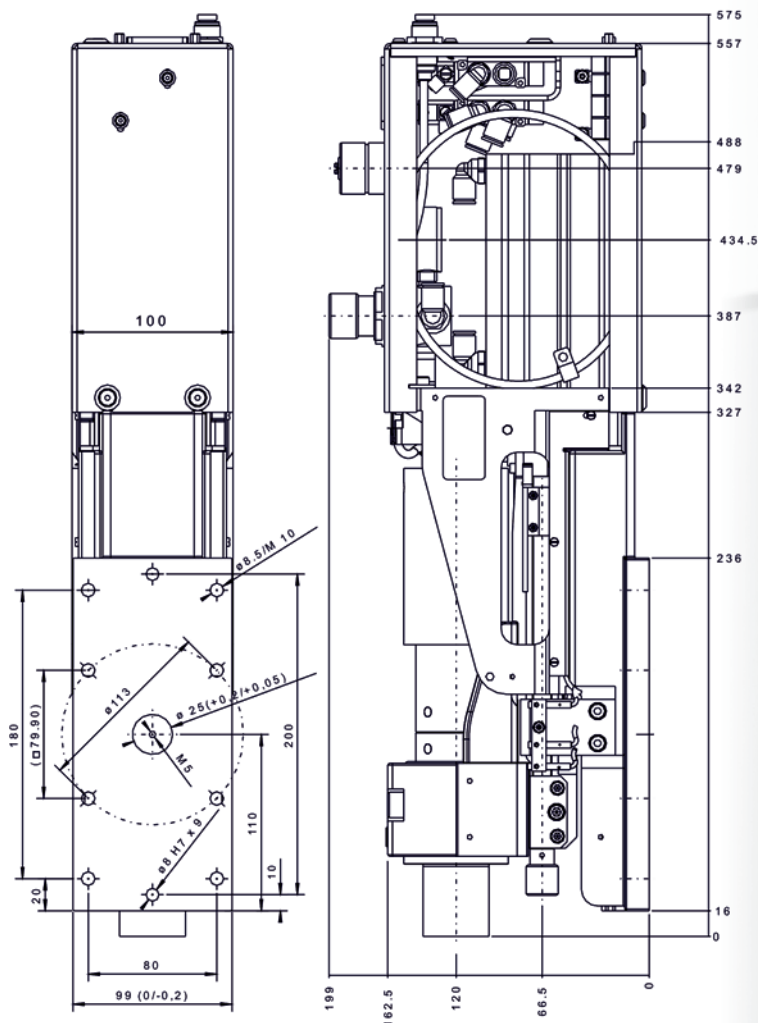

Modular design allows functional enhancement by addition of adequate components and options.

Attachment at the machine frame either of front or rear side; possibility of centering and orientation.

Integrated shock absorber to cushion fast return stroke properties of welding module slide.

Quick horn changeover; 360° rotation of vibrating unit.

Rigid slide construction with linear force transmission.

Solid state switches for home position, approach speed and ultrasonic release position.

All pneumatic components are integrated in the cover

„Plug and play“ concept with quick connectors for RF- power, compressed air and electronic signals on the top of the cover.

**Tec-B GmbH**  
**Fidlerstrasse 2**  
**CH-8272 Ermatingen**  
**T +41 (0)71 688 30 70**  
**F +41 (0)71 688 30 71**  
**info@tec-b.com**

