

OA 35-50

... ready for many solutions

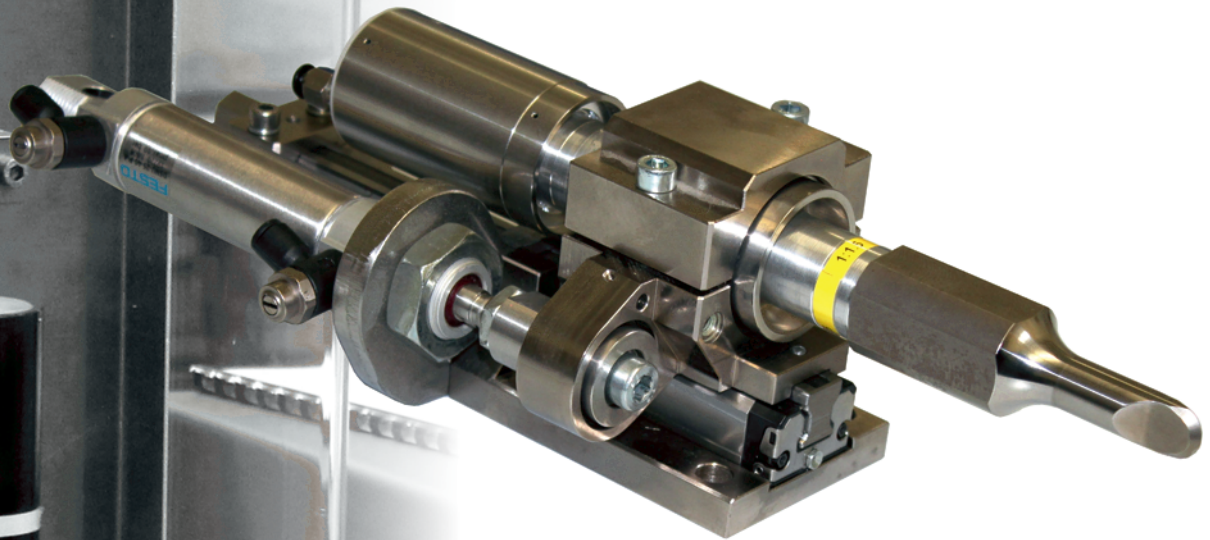

35kHz Ultrasonic Actuator for Special Machines
The compact and modular design of the unit facilitates and simplifies adaptation and utilization for any variety of ultrasonic welding applications.

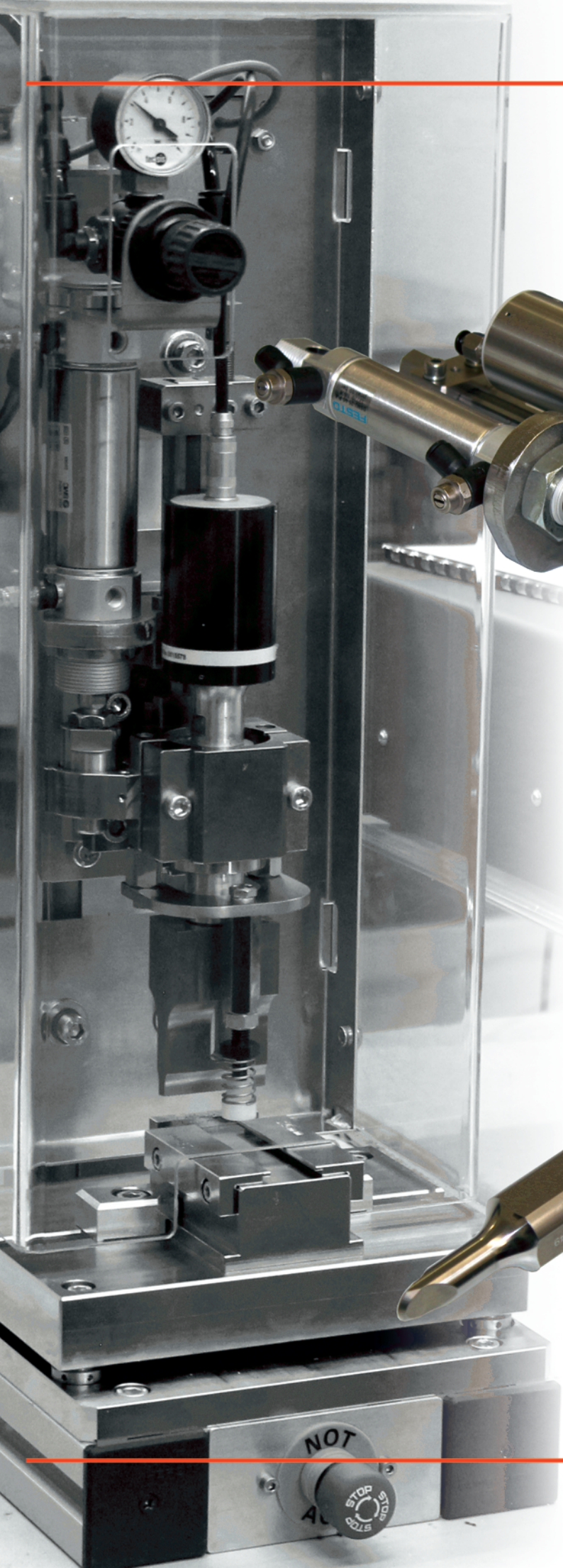
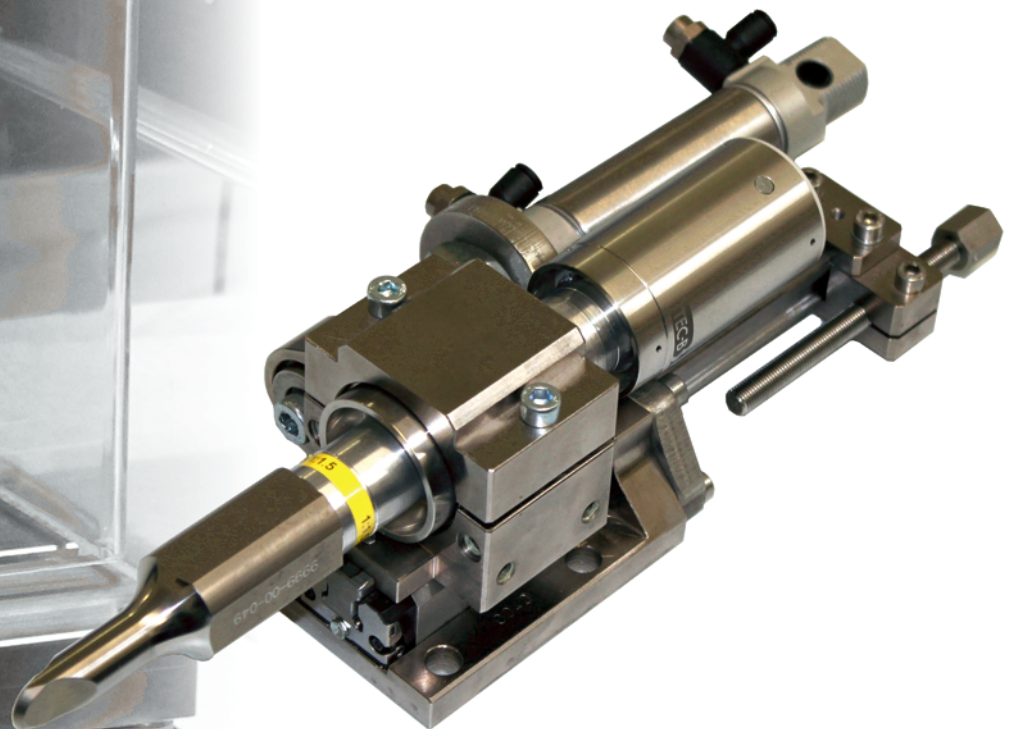

Tec-B GmbH
Fidlerstrasse 2
CH-8272 Ermatingen
T +41 (0)71 688 30 70
F +41 (0)71 688 30 71
info@tec-b.com

OA 35-50

Flexible System

Using the same components, the cylinder can be installed either on the left or on the right side of the vibrating unit. Alternatively to a machine specific solution or a trigger & interfacebox, it is possible to install the pneumatic components directly on the actuator by means of a special bracket. For continuous welding operations the bracket is prepared to integrate an additional valve for converter and horn cooling. The cooling air is led over a pipe to the horn.

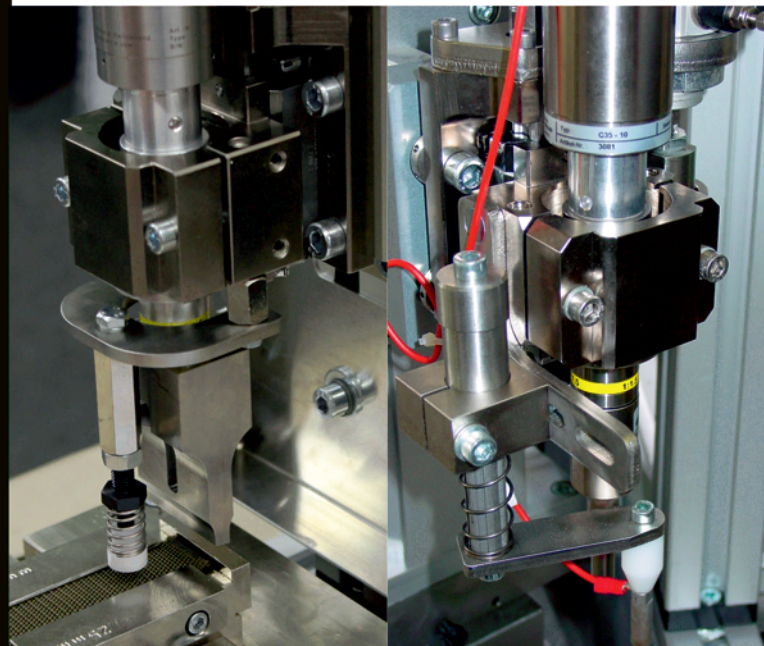
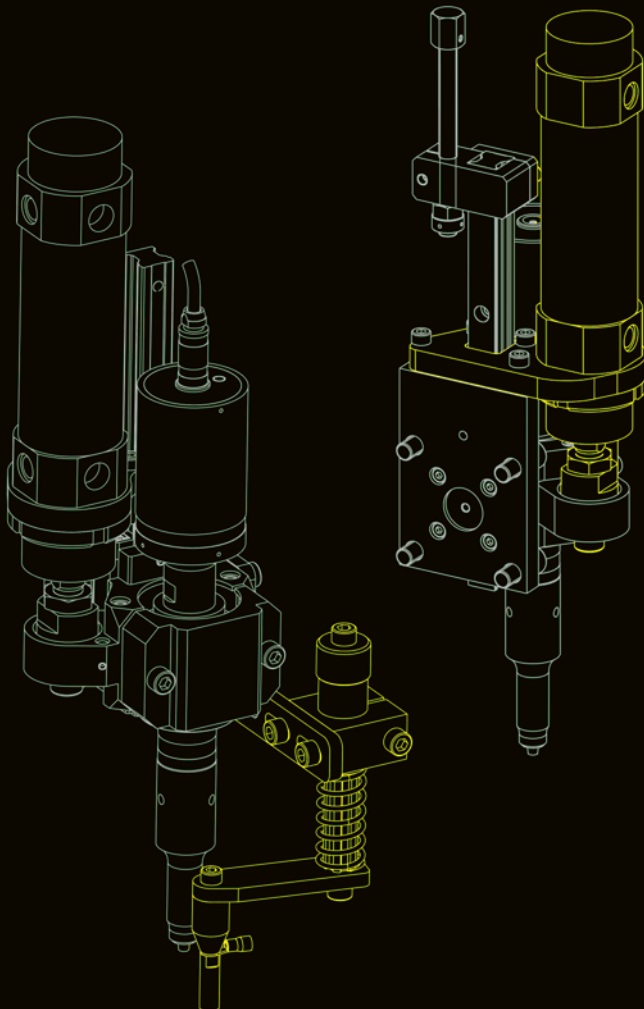
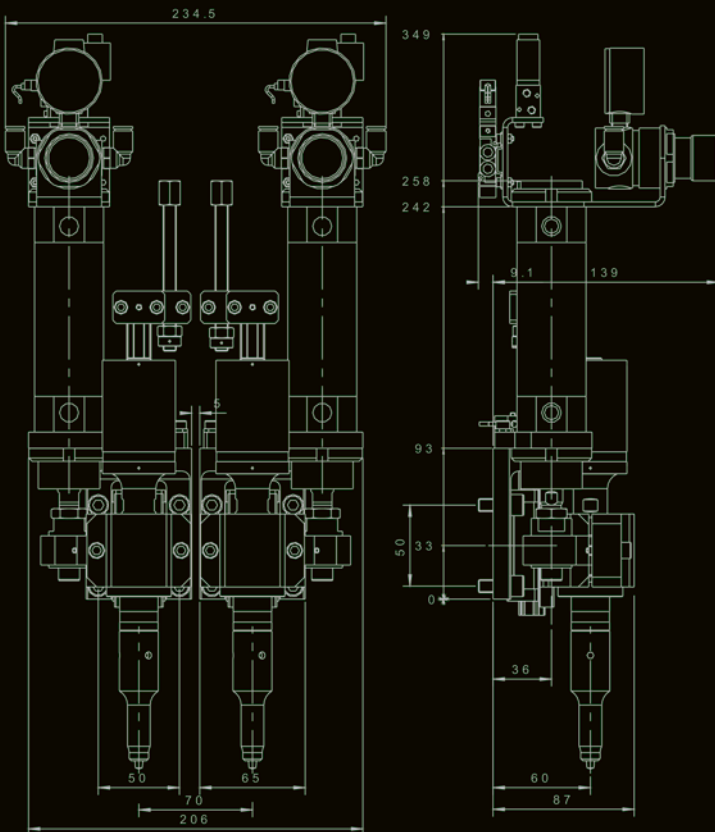

Superior welding results by selection of optimal force range.

The OA35 actuator is conceived to operate with cylinder of 40, 32 or 25mm diameter. Conversion by interchanging cylinders with the appropriate mounting plate and the cylinder rod coupling.
Stroke: 25 - 100mm

Accessories, also available as retrofit sets:

Foregoing downholder for securing the parts during the welding process. "Depth shut off" unit mountable on the mechanical stop to shut off US-power at the preset weld depth.

Customer specific accessories on demand.

Tec-B GmbH
Fidlerstrasse 2
CH-8272 Ermatingen
T +41 (0)71 688 30 70
F +41 (0)71 688 30 71
info@tec-b.com